

EE 2683

Project Based Learning (PBL) - 10%

Dr. A.M. Sharaf
(www.ece.unb.ca/sharaf)

Project Title: The Micro E-CAR Drive System

DUE: APRIL 2, 2007

Good Luck!

Objectives: The solar powered PV- Micro-E-CAR

1. To develop a unified functional model of a permanent magnet DC motor (PMDC) Drive driven by either a battery or photovoltaic panel for a photovoltaic powered small E-Car (Electric vehicle).
2. To test a low cost effective power electronic DC-DC chopper drive controlled by either a (PID) controller or a Bang-Bang slide mode controller (select either one).
3. Test the speed tracking dynamic response for a step reference and (Ramp up - Ramp down) Reference Speed Trajectory.

TIP: Use already built models in Matlab / Simulink software / Sim Power
(Use Dr. Altas's PV model)

The simple PMDC DC drive for mini/micro E-Car is shown in Figure 1.

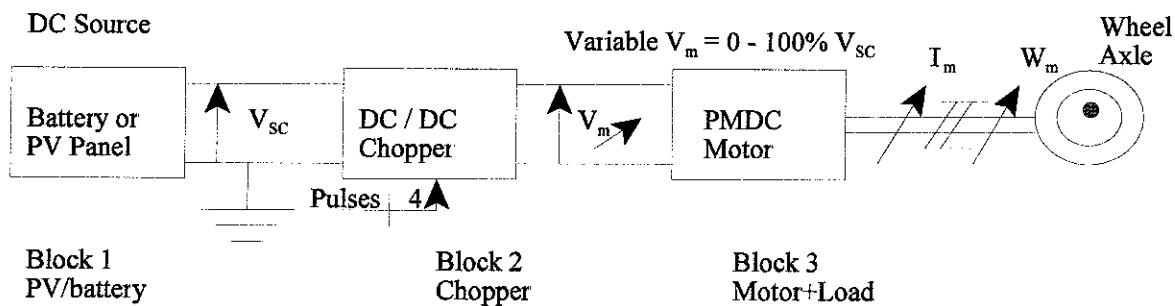

FIGURE 1: PMDC Drive for E- Car

** The best project will receive a prize donated by Professor A. Sharaf.

The (DC/DC) chopper is a 2 quad Mosfet triggered drive system and is shown in Figure 2.

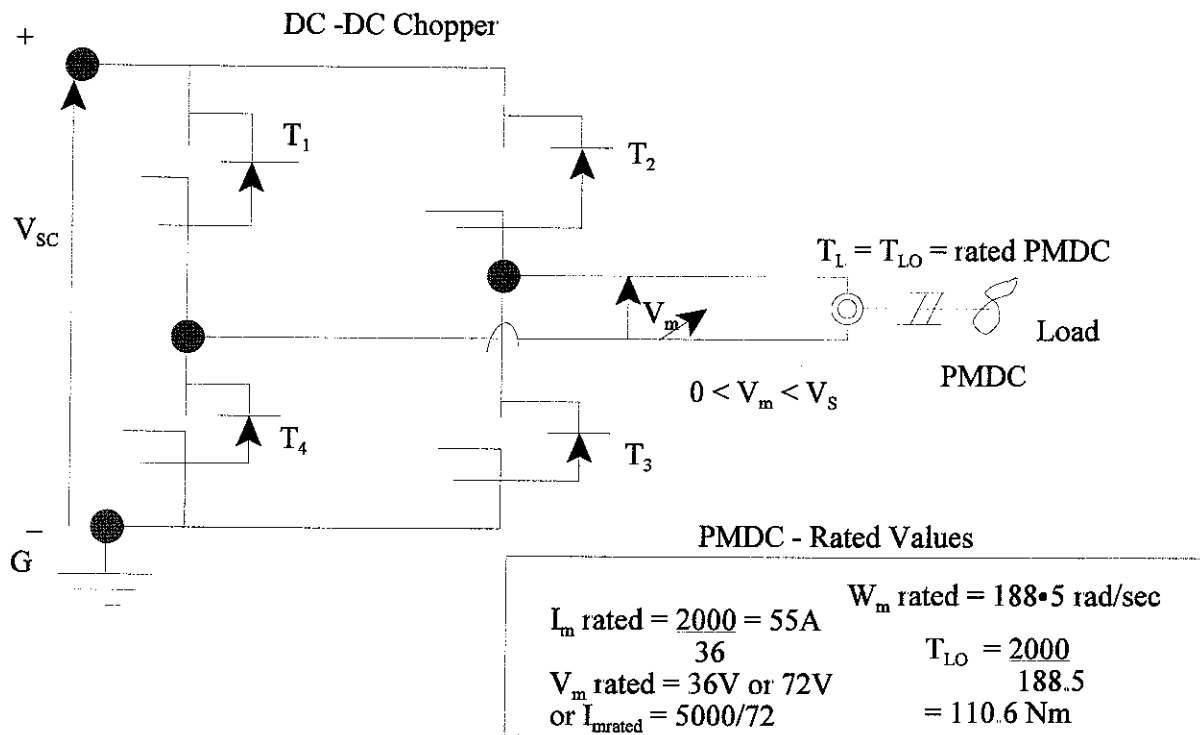

FIGURE 2: DC-DC Chopper Drive

The chopper is controlled by a pulse width modulated block to control duty cycle ratio α_D .

$$\alpha_D = \frac{t_{on}}{T_{S/W}} \quad \text{In order to vary the PMDC - voltage } V_m \text{ from } (0 - V_s) \text{ voltage range.}$$

The DC source can be either a DC Battery or the photovoltaic array panel mounted on the car roof top.

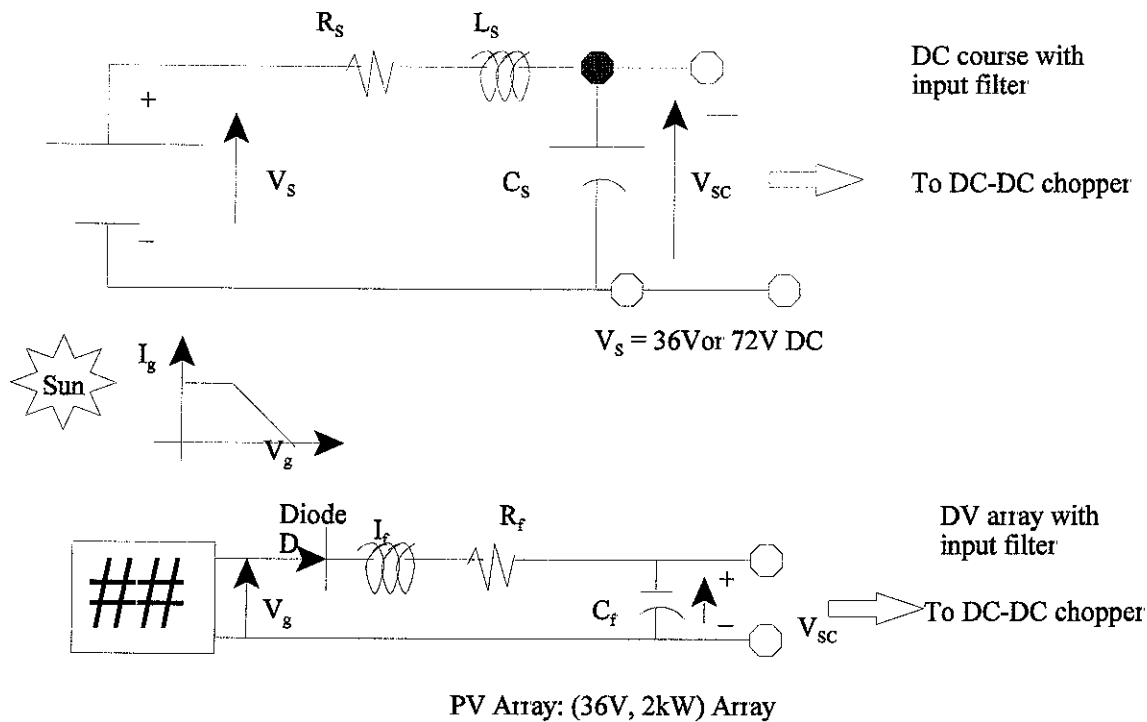

FIGURE 3: DC Source / DV Source

The motor is rated 36V or 72V DC at 2 kW-5kW with rated speed of 3600 rpm and the following parameters:

- { $R_m = 0.15 - 0.35 \text{ ohm}$
- { $L_m = 3 - 6 \text{ mH}$
- { $K_m = K_t - 0.20 \text{ v/rad sec (00.40-0.50 v/rad/sec for 72V 5 kW motor)} = \text{motor constant}$

The basic control scheme is a simple PID or Bang-Bang variable structure / slide mode controller (select only one) as shown in Figure 4A and Figure 4B.

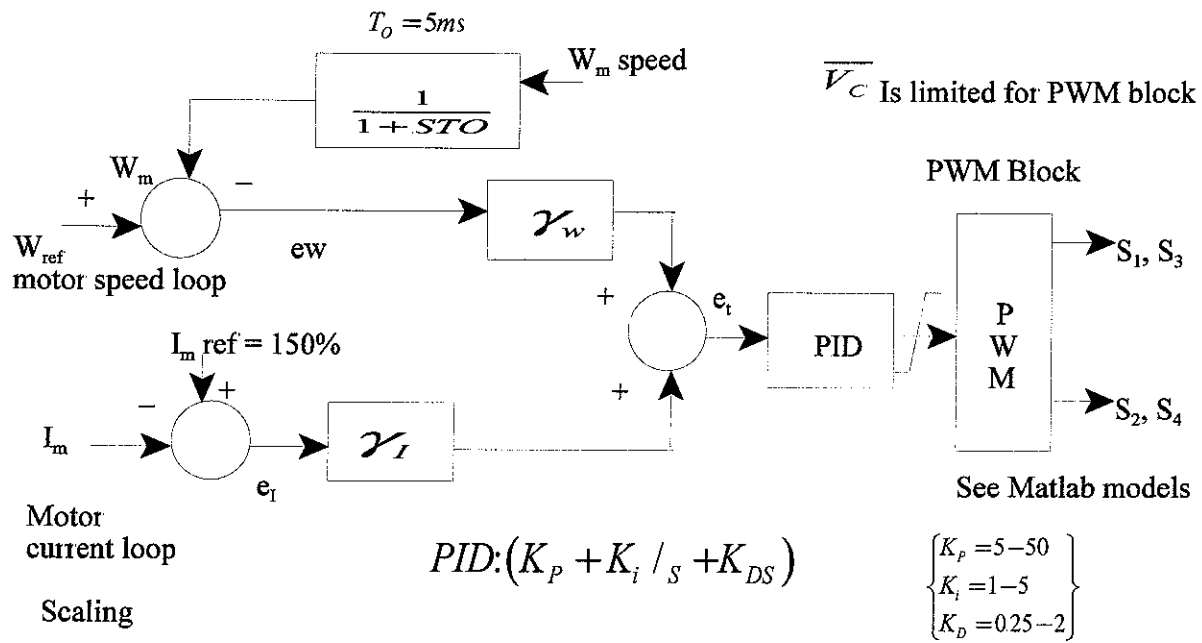

FIGURE 4A: PID Dual Loop Limited Current Loop Speed Controller with Motor Current

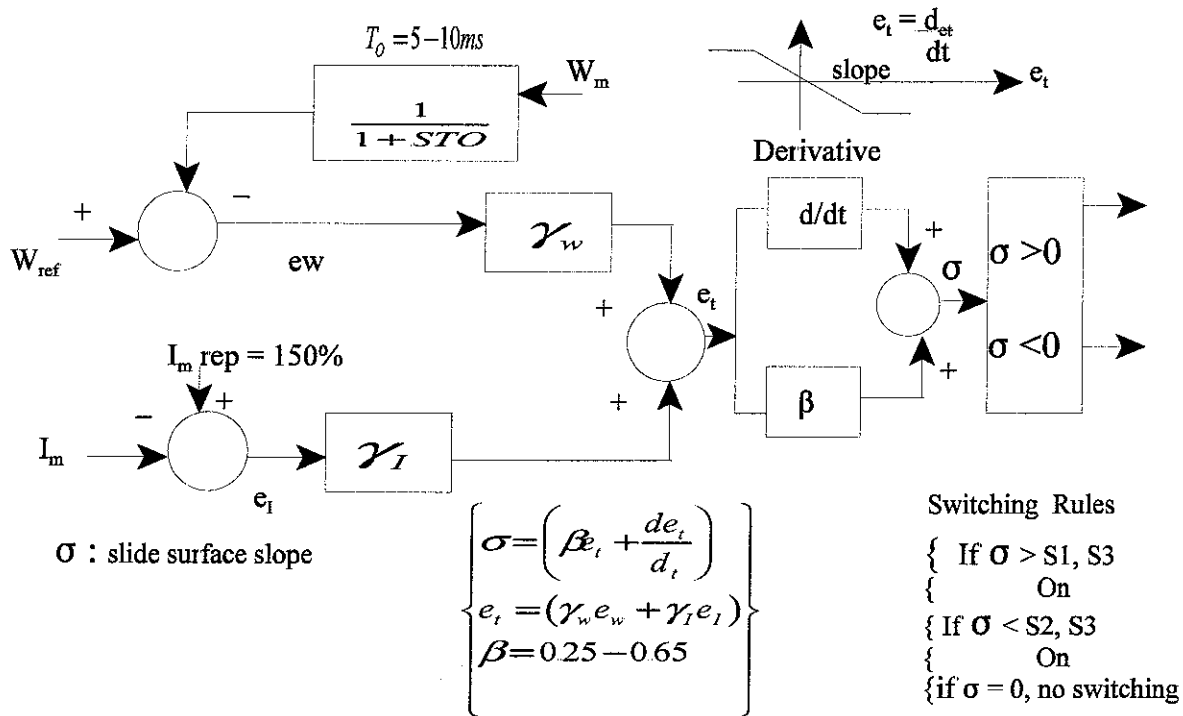
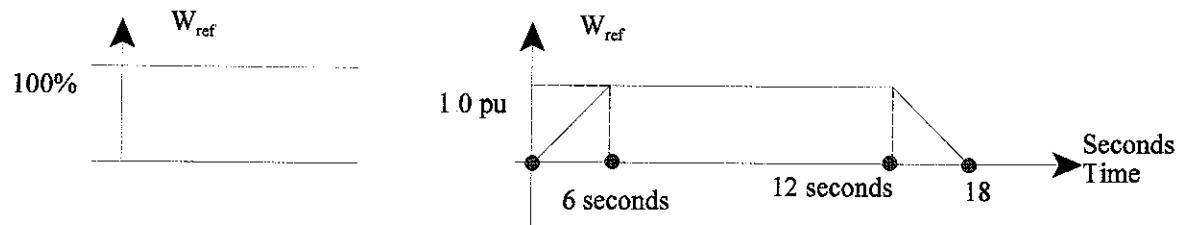

FIGURE 4B: Bang-Bang Limited Current Variable Structure/Slide Mode Dual Loop Controller

(A) Test the full PMDC motor drive for step speed = (100% or 1pu) for ramp up / ramp down as shown.



- (B) Plot all digital waveforms (V_s , I_s , V_M , I_M , P_M , T_M , W_M) versus time.
- (C) Plot control parameters, signals, (e_w , e_p , e_r , σ , V_C) and switching - signals ($S_1 = S_3$, $S_2 = S_4$).
- (D) $S_2 = S_4 = \overline{S_1} = \overline{S_3}$ Complementary switching of the 2 Quadrant DC-DC chopper.
- (E) Test all under torque = T_L (rated torque).

TIPS:

1. Use Matlab / Simulink / Sim Power already built software blocks for PMDC, DC-DC drive.
2. Use Dr. Ismail Altas photovoltaic array built-in (V_g - V_s - I_g) model.
3. Use the PWM pulse width modulation blocks available at Matlab / Simulink software
 - (i) for SPWM block select $F_{s/w} = 3500 - 8500$ Hz up to 10,000 Hz.
 $0 < m < 1.0$
 - (ii) for on-off (PWM) select parameters as defaults in Matlab.

For Extra Help / consulting see graduate student TA's for EE 2683 (all in Room H3):

- Mr. Saleem email i6v1a@unb.ca
- Mr. Aljankawey email o6uw1@unb.ca
- Mr. Wang email o13iv@unb.ca
- Mr. Mahasneh email q7656@unb.ca

For use of PV-Block model see Dr. Altas at ihaltas@unb.ca (Use Dr. Altas's PV Model)
www.ihaltas.org

GOOD LUCK!