

*Peer Corrected*

# A NOVEL POWER QUALITY ENHANCEMENT SCHEME IN LOW VOLTAGE DISTRIBUTION SYSTEM USING MODULATED POWER FILTER COMPENSATOR

*A.M. Sharaf, SM IEEE*

Dept. of Electrical and Computer Engineering  
University of New Brunswick  
sharaf@unb.ca

*Wei Wu*

Dept. of Electrical and Computer Engineering  
University of New Brunswick  
a214g@unb.ca

**Abstract-** This paper presents a novel SPWM-switched modulated power filter compensator (MPFC) to enhance power quality in low voltage distribution systems under unbalanced and fault conditions. The MPFC is controlled by a dynamic tri-loop controller. The purpose of this dynamic controller is to minimize switching transients, maximize power/energy utilization and to improve power factor under unbalanced load and fault conditions.

**Key words:** Low Voltage Power Distribution System, Power Quality, Power Factor, Modulated Power Filter.

## 1. INTRODUCTION

The operation of Low Voltage distribution systems under both balanced / unbalanced, normal/fault conditions has been one of the most concern problems for the electric utility industry. Usually, a three phase, 4 wire systems are widely used for commercial centers and large residential loads to reduce the effect of any unbalanced phase load. The neutral wire is the neutral of the three phase secondary windings and is usually solidly grounded. When the phase loads are balanced, the neutral return current is near zero. When the three phase electric load is severely unbalanced or there exist fault conditions, the neutral current can become large and equals to the residual vector of phase currents. [1] The large current in neutral wire represents a serious public safety hazard, and may also cause damage of equipments. In order to decrease the current flowing to the ground and the danger which people and equipment will face, a dynamic novel MPFC scheme shown in Fig 1 was developed by the first author is used. The novel MPFC is controlled by a Tri Loop Variable Structure Sliding mode error driven error scaled dynamic controller developed by the First Author.

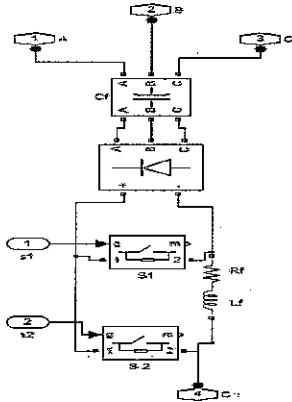

Figure 1: Modulated Power Filter Compensator Scheme

A high impedance fault (HIF) is characterized by having a resistive value sufficiently high that results in a low magnitude fault current which is not detected by conventional over-current protection, such as fuses and over-current relays. [2] In today's electric utility industry, the detection of high impedance faults (HIF) on electrical distribution systems has been one of difficult problems. Usually, The Arc-nature of all (HIF) faults are characterized by very low level fault current is also rich in low harmonic content and high frequency noise spectra. [1] The significance of these previously undetectable faults is that they represent a serious safety hazard to humans and animals. Using Waveform pattern identification techniques can result in a simple and accurate detection scheme using time domain voltage and current signals. Other

techniques developed by the first author encompass Neutral Characteristic-Residual Harmonics, Excursion Harmonic-Vector, Frequency-Based Nonlinear Temporal Transformations and Artificial Neural Network.[1,3] This paper presents the operation for 3 phase-4 wire unbalanced /balanced , normal and faults case with novel simple MPF modulated power filter located at the load terminal

## 2. Digital Simulation Model

### 2.1 System Description:

The investigated Low Voltage distribution /utilization system use 3 phase 4 wires system which is widely used for large residential building and commercial load centers.

The main purpose of using the novel MPF Scheme is to decrease the big current flowing to the ground to an acceptable value which will not be dangerous to people and equipment. The sample study distribution systems are shown in Fig2. The major parameters of system are shown in Table 1. The major components of the sample study systems include:

1. Three phase-four wire AC power supplies.
2. Novel MPFC Filter
3. Tri-loop dynamic error driven error scaled-SPWM controller
4. Loads: Single phase load: balanced nonlinear RL load, unbalanced nonlinear RL type and nonlinear type converter type load.

EE6630 Project 3 The Model of Low voltage Distribution Systems under Balanced Condition ( Phase a Short Circuit)

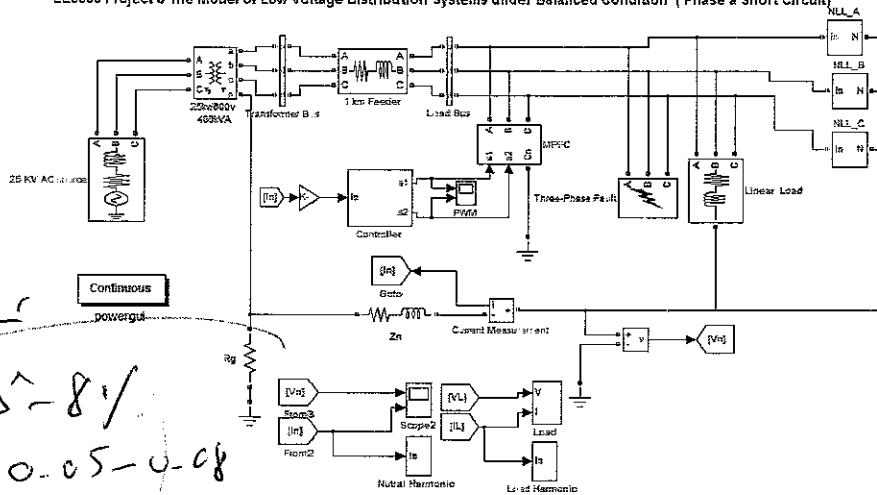

Figure 2 Matlab- Simulink functional model of the 3Phase-4 Wire Model

Table 1. System parameters

Three phase AC source		Non-Linear Load	
Based Voltage	25 Kv	a Active Power	54KVA
Frequency	60 Hz	a Reactive Power	26KVA
S.C Level	<del>400MVA</del>	b Active Power	54KVA
<b>Power Transformer</b>		b Reactive Power	26KVA
Nominal Power	400 MVA	c Active Power	72KVA
Frequency	60 Hz	c Reactive power	35KVA
Prim. Voltage	25 Kv	<b>Fixed Capacitor</b>	
Sec. Voltage	600 <del>KV</del>	Cf	0.885uF
Magnitization Resis.	500	<b>SPWM Model</b>	
Magnitization Reac	500	$\gamma_i$	0.8
<b>Transmission line (1Km )</b>		$\gamma_n$	1.8 $\gamma_n$ ref = 0.15

system  
 $X = 5 - 8j$   
 $S = 0.05 - 0.08j$   
 $X/R = 10$

15  
 20MVA

Resistance	0.33 Ω	$\gamma_h$	1.2
La, Lb and Lc	1.1mH	$F_{sw}$	190
<b>Linear Load</b>		Time Delay $T_o$	0.001 s
Active Power	180KVA	<b>PI Controller</b>	
Reactive Power	88KVA	$K_p$	5
<b>MPF Filter</b>		$K_i$	1
Ca, Cb and Cc	885uF	$K_d$	0
Rf	0.002	<b>Saturation Limitation</b>	
Lf	0.12 mH	Upper limit	2
<b>Grounding Resistance</b>		Lower limit	0
Rg	0.5	<b>Balanced Non-Linear Load</b>	
<b>Neutral Wire</b>		Universal Bridge	
Rn	0.1	Active power	64KVA
Ln	0.5mH	Reactive power	48KVA

## 2.2 Dynamic Tri-Loop Error Driven Slide Mode Controller

The novel tri-loop dynamic controller shown in fig 4 was developed by the First Author and uses a variable structure Bang Bang slide mode control scheme driven by three dynamic error regulating loops: (rms neutral current, minimum neutral rms current, harmonic current ripple) error-tracking loops. The purpose of this three multi-loop dynamic controller structure is to minimize switching transients, maximize power/energy utilization and to improve power factor under unbalanced load conditions. The total error signal ( $e_t$ ) is the sum of the three basic dynamic scaled loop errors. The loop weighing factors is assigned to ensure loop time. [3]

The novel dynamic tri loop error driven Bang-Bang Slide Mode Controller comprises three basic regulating loops.

1. The main rms neutral current ( $I_n$ ) tracking loop is to minimize neutral return current or residual current.
2. The minimum neutral rms current ( $I_{ref} = 0.15$  pu) reference tracking loop.
3. The low neutral current- harmonic ripple loop is to enhance power quality.

The novel tri-loop dynamic controller is governed by the equation (1) and (2):

$$\sigma = \zeta e_t + \frac{de_t}{dt} \quad (1)$$

$\sigma$  is defined as the sliding surface slope, and  $e_t = \gamma_i e_i + \gamma_n e_n + \gamma_h e_h$ .

$$\zeta = \zeta_0 + K_e \zeta_1 \quad (2)$$

The dynamic global error magnitude  $K_e$  is defined as follows

$$K_e = \sqrt{(\gamma_i e_i)^2 + (\gamma_n e_n)^2 + (\gamma_h e_h)^2}$$

The Sliding surface parameters are usually selected by Trial and Error and was optimized at  $\zeta_0 = 0.15 - 0.25$ ;  $\zeta_1 = 0.3 - 0.5$ .

The output switching signals is determined [4] by of the dynamic Sigma –Sign (negative or positive).

If  $\sigma > 0$ , Switches  $S_1 = \text{On}$  and  $S_2 = \text{Off}$

if  $\sigma < 0$ , Switches  $S_1 = \text{Off}$  and  $S_2 = \text{On}$

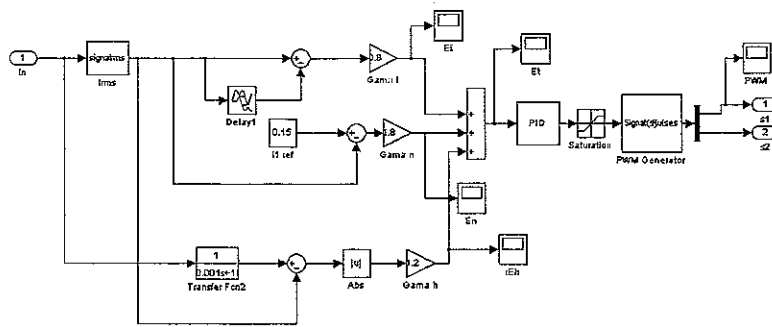

Figure 4 Tri loop dynamic Variable structure-sliding mode control Scheme

### 3. Simulation and Validation

The novel Modulated Power Filter-MPF device is effective low cost energy utilization and power quality enhancement solution for reducing switching transients and load excursions using the low cost hybrid modulated tuned arm power filter and a switched capacitor bank compensator[3]. In order to validate the proposed Novel Dynamic Compensator, four simulation cases are investigated in this project.

- (1) balanced nonlinear load without novel dynamic compensator
- (2) balanced nonlinear load with novel dynamic compensator
- (3) unbalanced nonlinear load without novel dynamic compensator
- (4) unbalanced nonlinear load with novel dynamic compensator

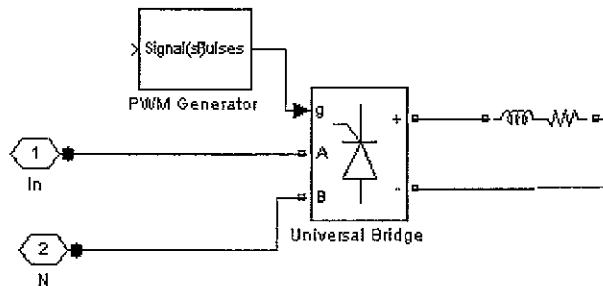

Figure 5 Converter type nonlinear load model

Short-circuit fault condition in phase a simulated from 0.1 to 0.24 sec and for the two cases without and with MPFC under balanced nonlinear loads.

Matlab-Simulink/Sim-power Software was also used to design, test, and validate the effectiveness of the proposed MPFC device and the associated dynamic SPWM controller. Comparisons of each case result obtained from different unbalanced and fault conditions are shown in Appendix Figures A1-

### 4. Conclusion

The paper presents a novel low cost Facts Switched Modulated Power Filter (MPFC) device for voltage compensation of Low Voltage distribution systems under balanced / unbalanced, normal and fault conditions. This compensation device is regulated by a dynamic error driven tri-loop Slide mode Controller to reduce the effect of switching transients, faults and load disturbances in any existing commercial and large residential load centers. The simulation results show that the power factor can be effectively improved (from 0.5 to 0.9) when the novel dynamic compensator is used in the normal unbalanced nonlinear load case. In addition, the phase voltage can be maintained around 1pu and the transient over-voltages and surge type inrush currents are also damped. For the balanced nonlinear load fault case, voltage sag caused by phase short circuited can also be compensated by this novel dynamic MPF. It is observed that the power factor is also increased from 0.5 to 0.8. By comparing the results of four sample simulation cases, it is concluded that the novel dynamic MPF-Facts device with the Slide mode-SPWM dynamic controller developed by the first author is an attractive low cost and efficient Voltage stabilization

and power factor correction device that also improve power quality and efficient-utilization of three phase –four wire Residential and Commercial Loads.

#### REFERENCES

- [1] A. M. Sharaf and GuangSheng Wang, 'High Impedance Fault Detection using Feature- Pattern Based Relaying,' IEEE Trans., (2003) pp 222-225.
- [2] Craig G. Wester, 'High Impedance Fault Detection on Distribution Systems', GA,30092 USA
- [3] A.M Sharaf and Roshan Chhetri, ' A Novel Dynamic Capacitor Compensator /Green Plug Scheme For 3 Phase-wire Utilization Loads',
- [4] A.M.Sharaf and Liang Zhao, 'A Novel Voltage Stabilization Scheme for Standalone Wind Energy Using a Facts Dual Switching Universal Power Stabilization Scheme', 2005

#### Appendix

##### Case 1 and Case 2:

##### Balanced Fault & Without MPF

##### Balanced Fault & With MPF

(Phase- A short circuit case)

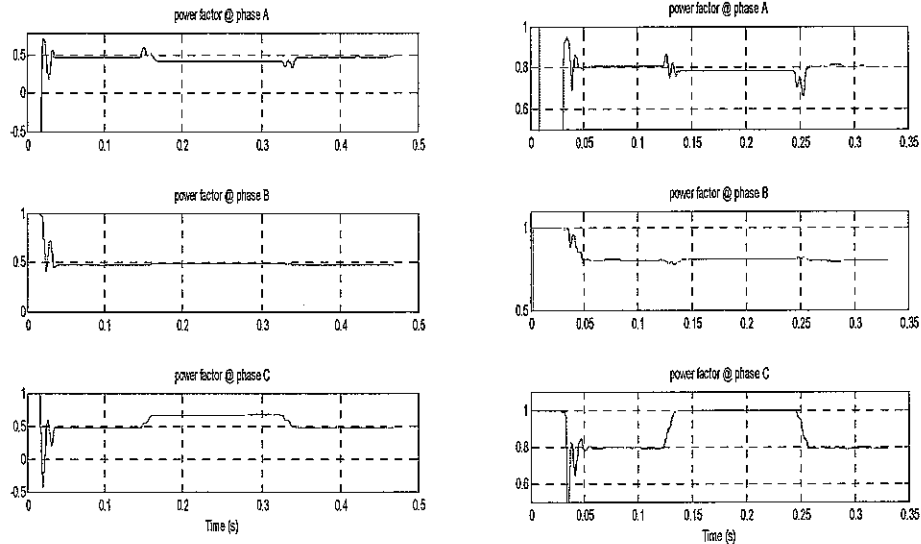

Figure A1: Load Power Factor

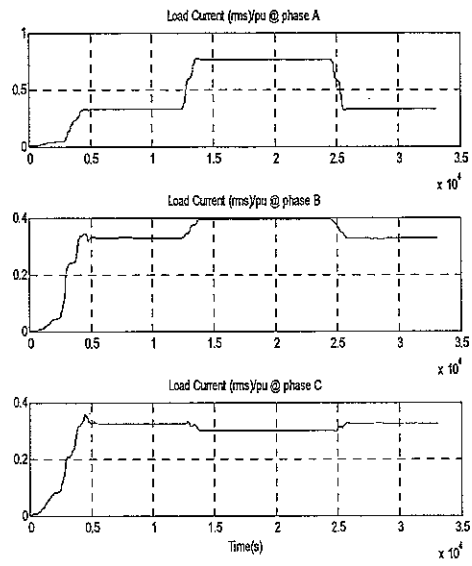
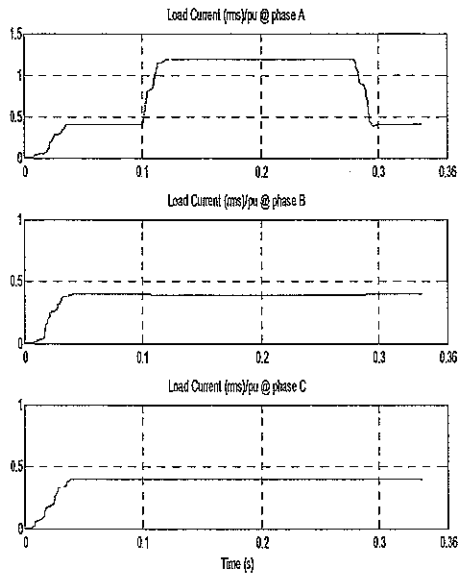

Figure A2: Load Current (rms)

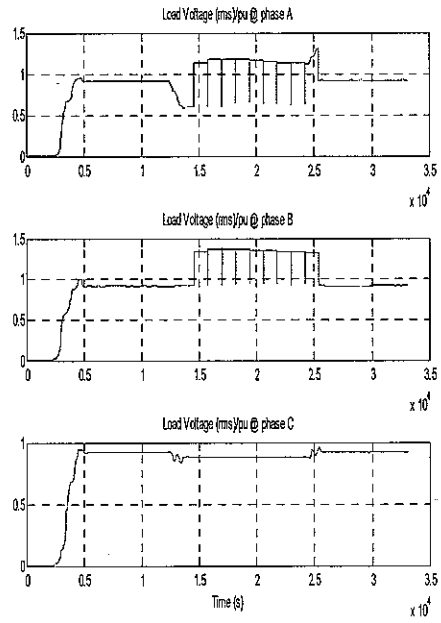
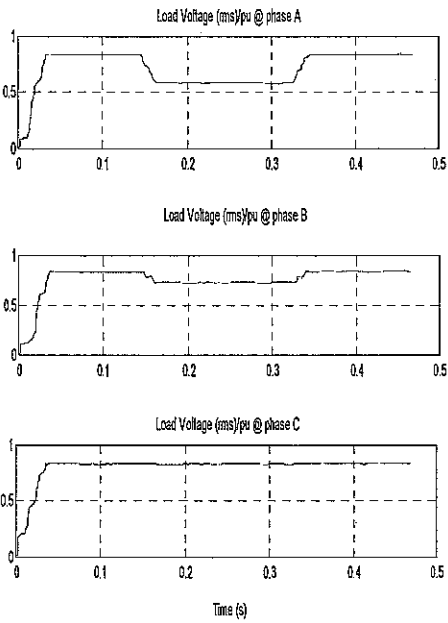

Figure A3: Load Voltage-(rms)

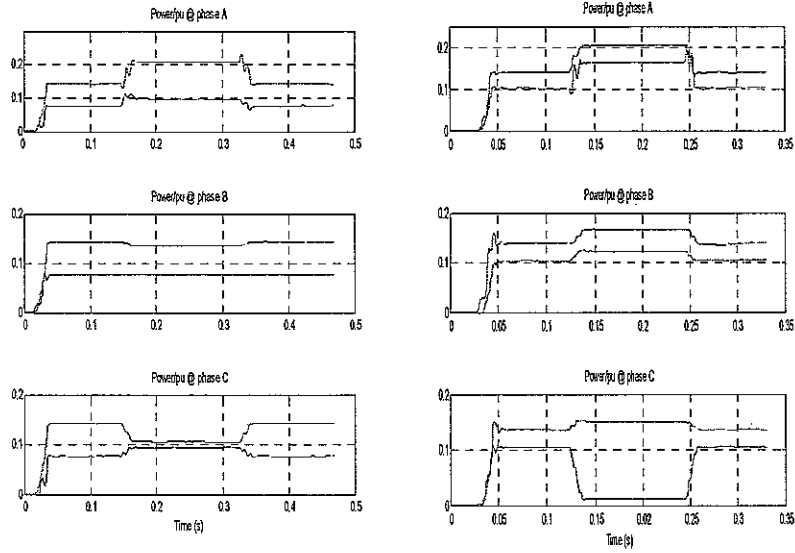

Figure A4: Power

Balanced Fault with compensator S1 and S2

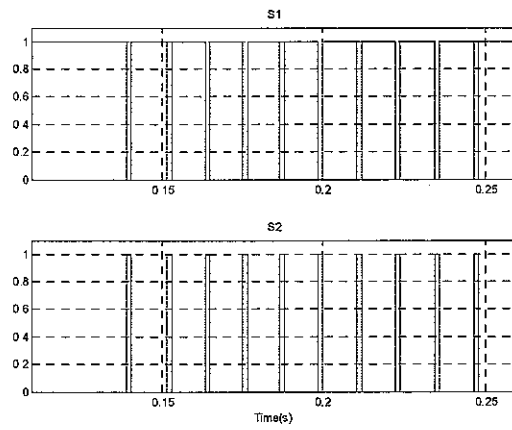

Figure A5

Balanced Fault with compensator Ei, En, rEh and Et

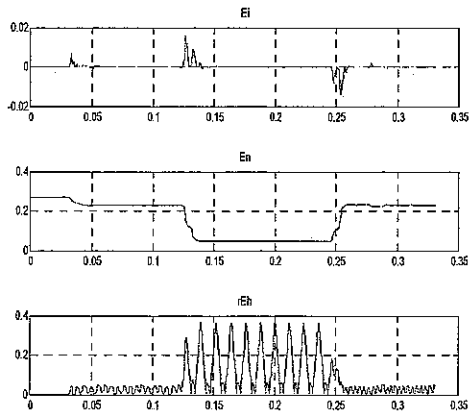

Figure A6

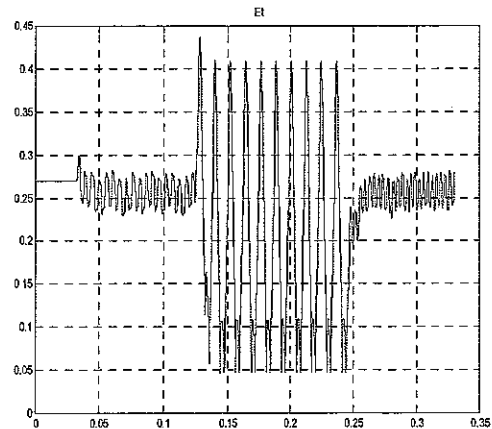

Figure A7

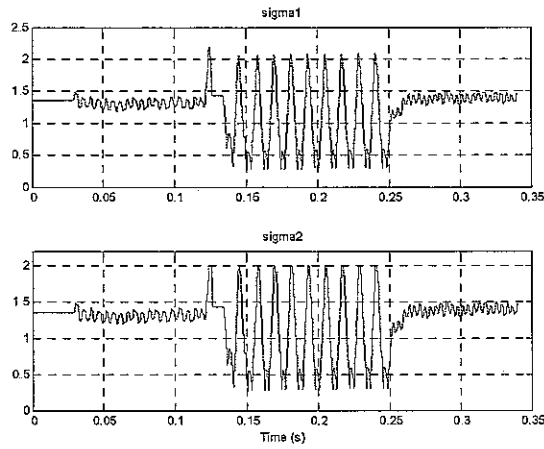

Figure A8 Balanced Fault with compensator Sigma vs Time

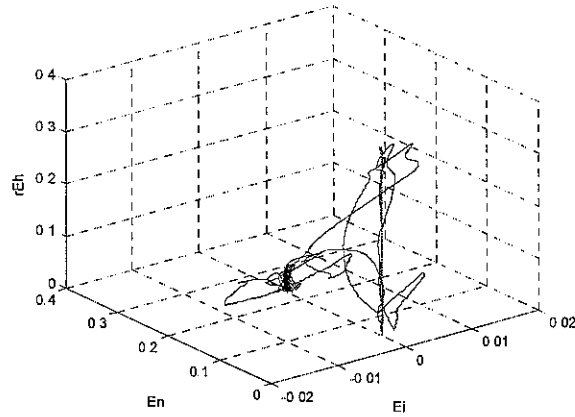
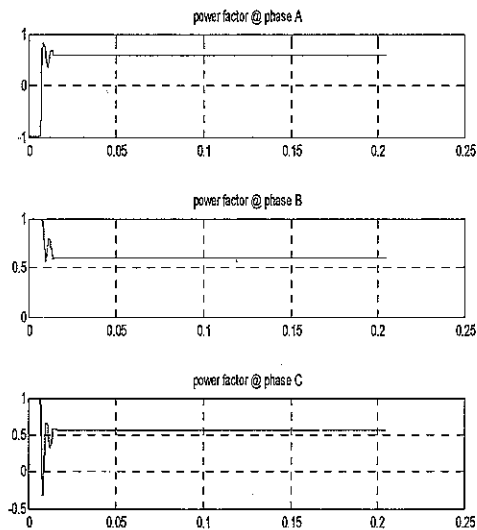

Figure A9 Balanced Fault with compensator  $E_i$ ,  $E_n$  and  $r_{Eh}$  3D

**Case 3 and Case 4:  
Unbalanced & Without MPF**



**Unbalanced & With MPF**

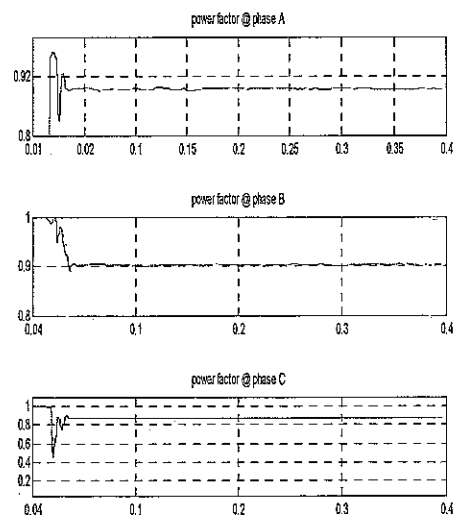

Figure A10: Load Power Factor

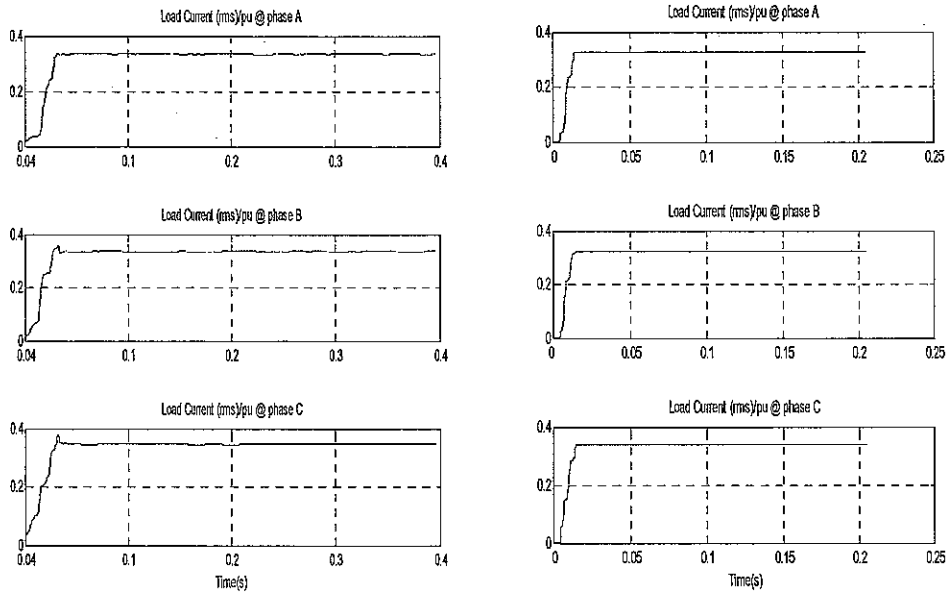

Figure A11: Load Current (rms)

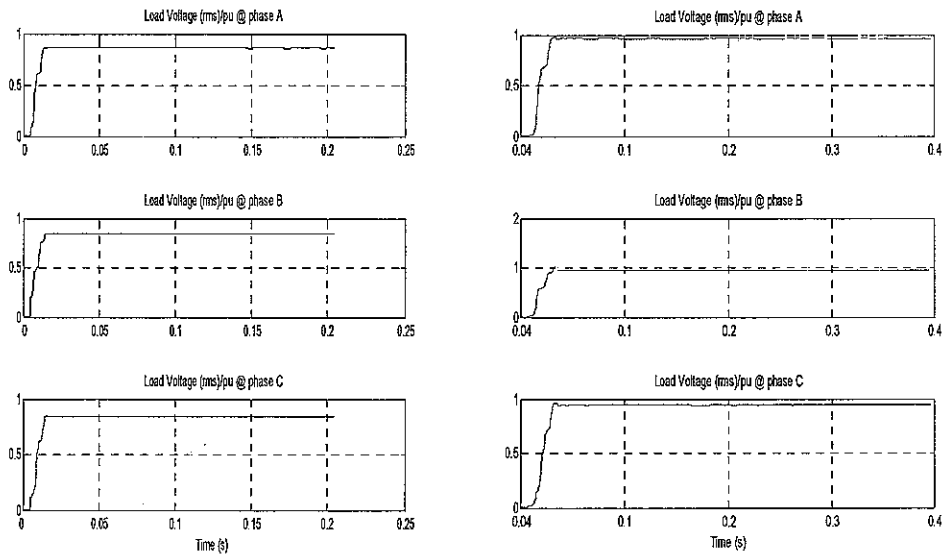

Figure A12: Load Voltage- (rms)

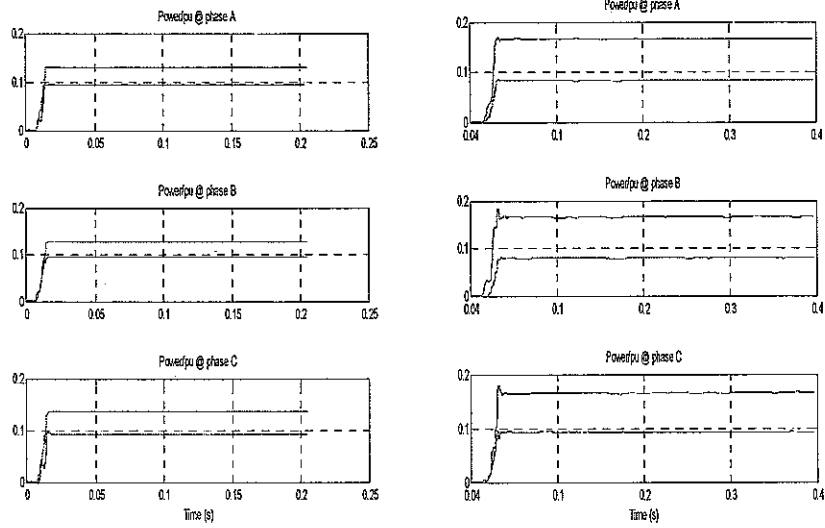

Figure A13: Power

Unbalanced - Neutral  $V_n$  and  $I_n$  without MPF

Unbalanced- Neutral  $V_n$  and  $I_n$  with MPF

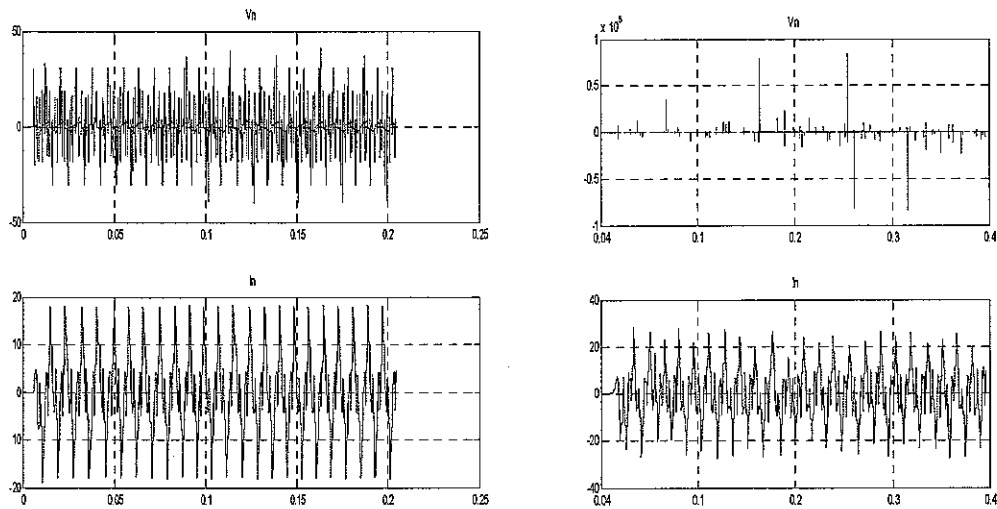

Figure A14: Neutral Voltage and Current signals

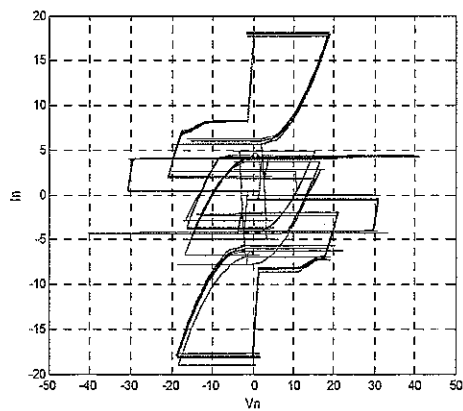

Figure A15: Unbalanced Neutral  $I_n$  and  $V_n$ - 2D

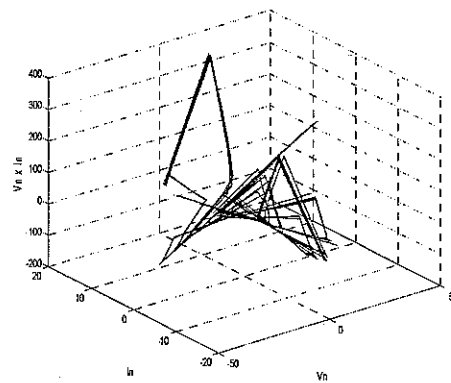

Figure A16: Unbalanced Neutral  $I_n$ ,  $V_n$  and  $V_n \times I_n$  3D

Unbalanced Load with compensator Ei, En, rEh and Et

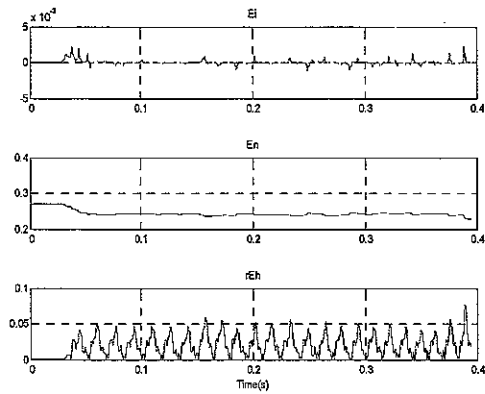

Figure A17

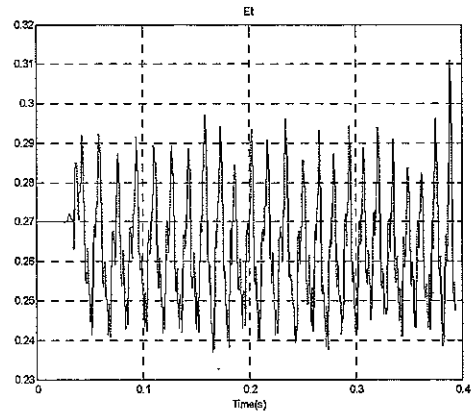

Figure A18

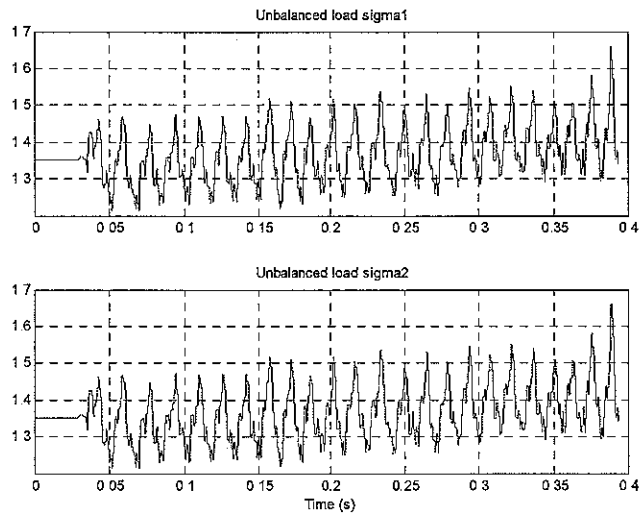

Figure A19 Unbalanced Load with compensator Sigma vs. Time

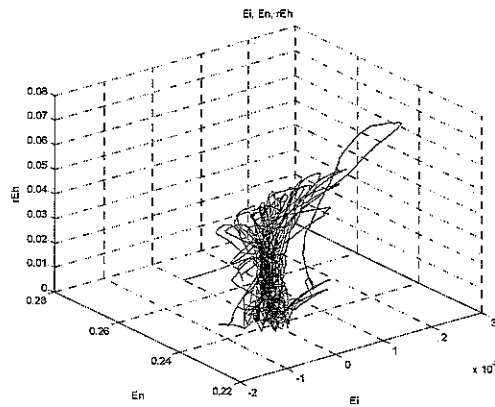

Figure A20 Unbalanced Load with compensator Ei, En and rEh 3D